

VCH SERIES

Indoor & Outdoor Rental LED screen

CONTENTS

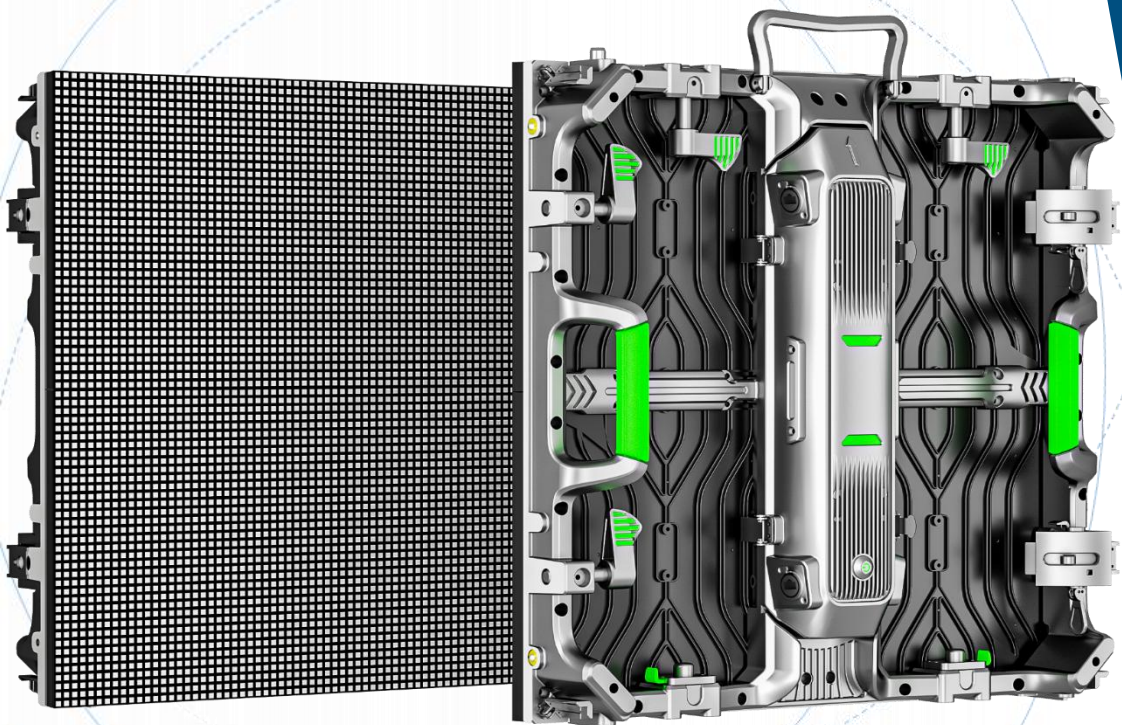

01

Product Overview

02

Scorpe of Applicatons

03

Product Features

04

Product Specifications

PART. 01

Product Overview

Design for rental and indoor, outdoor applications

Product Overview

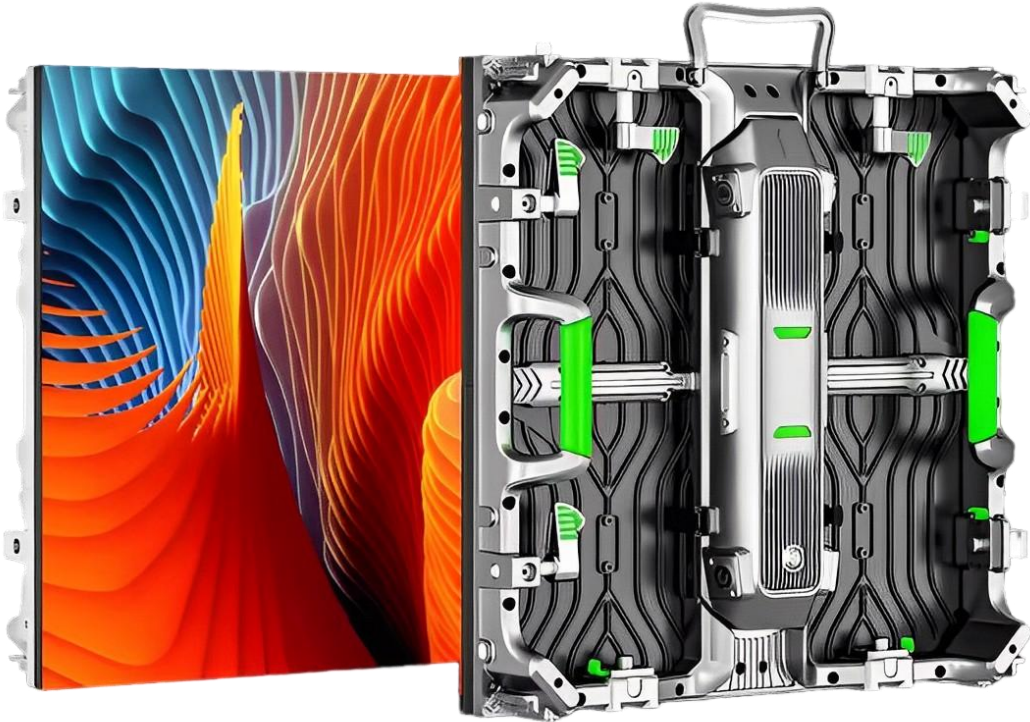

VCH Series

Indoor: P2.6/3.9
Outdoor: P3.9/4.8

- Super lightweight and slim 6.8KG/ pcs
- Curve optional -10° $+15^{\circ}$
- Front/Rear Easy Maintenance 100%
- Energy Saving Avg.180w/sqm
- Creative Installation Corner Optional 45° /pcs

Product Detailed Vision

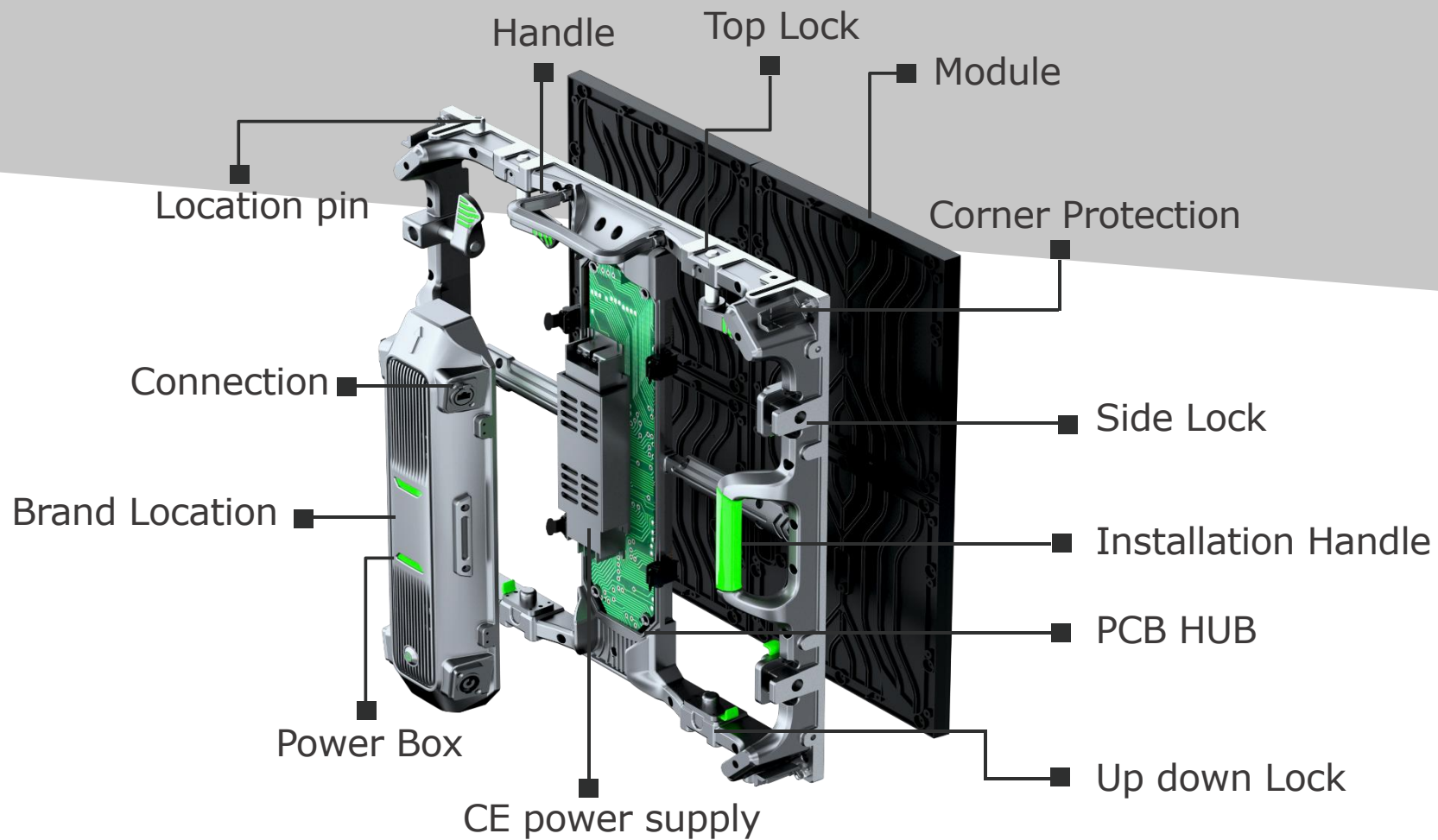

PART. 02

Scorpe of Applicatons

Widely applications, curve and corner installations

Scorpe of Applicatons

- Multi-assembly
- Widely application
- Design for quick rental
- Curve or corner installations

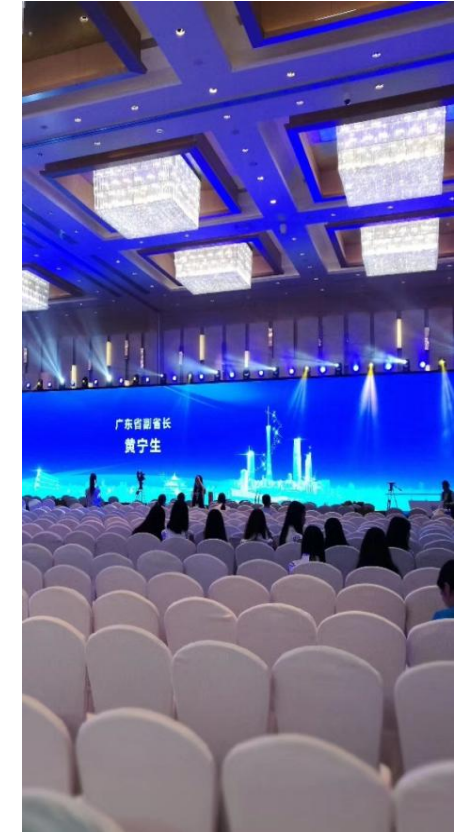
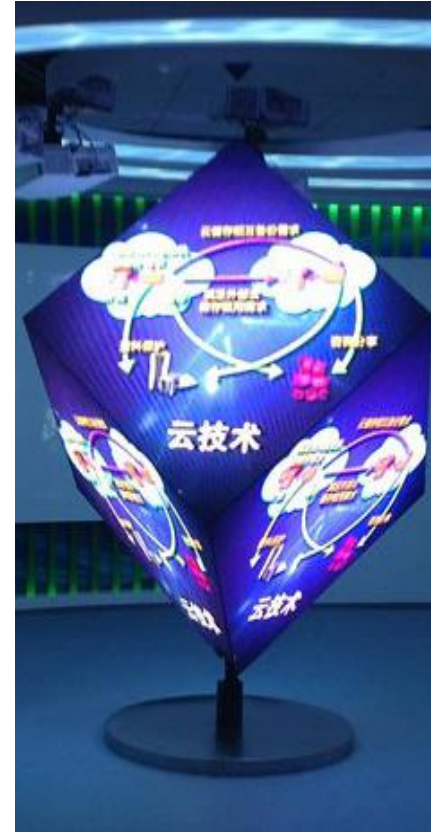

Events, commercial shows, Conference, Performance, Advertising

PART. 03

Product Features

Design with fast rental and super slim

Apperance

COMPACT APPERANCE

- Fancy slim cabinet, and Fast lock with one man installation design, save the strength and time
- Curve lock with -10 +15 degree
- 45 degree edge cutting optional

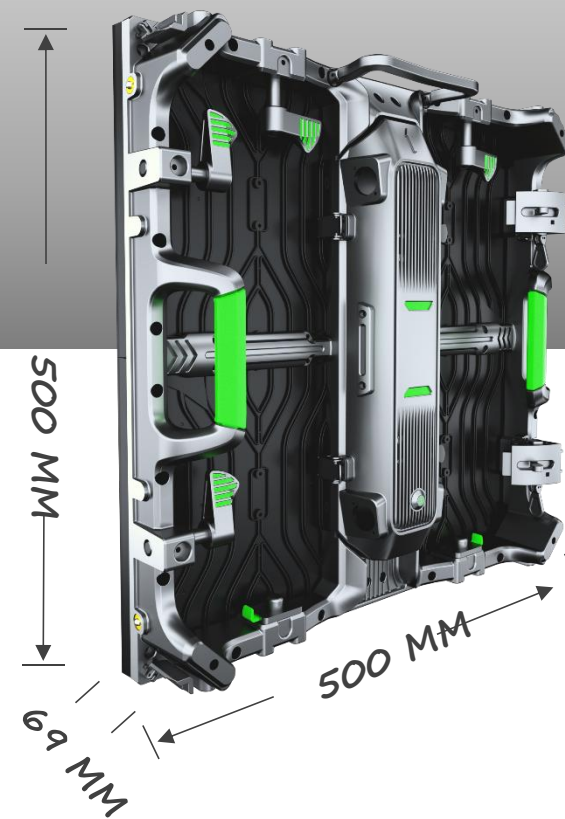

MULTI-CABINET SIZES |

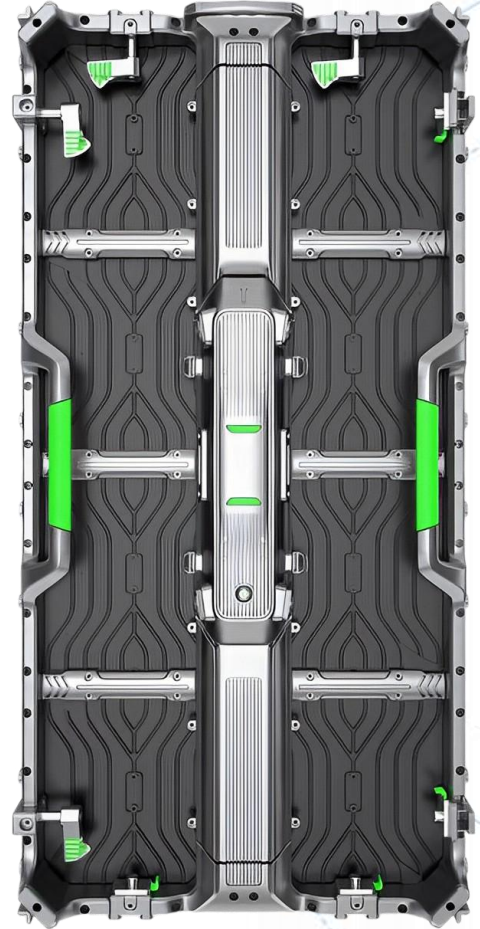

500x1000 mm

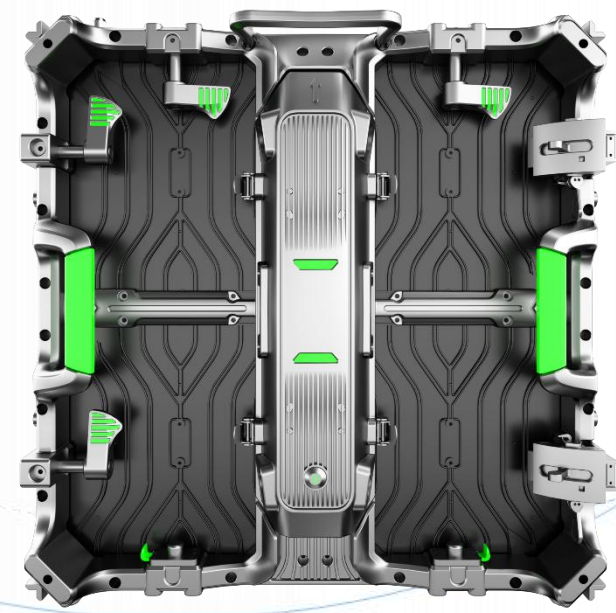

500x500 mm



500x500 mm 45° cut

Typical and special solutions, Widely application



Hanging

Lighter weight and better thickness control of our cabinet with fast locks makes hanging more efficiently



Stacking

Rigid and strong stacking frame ensure the stability of product installation



CORNER PROTECTOR FROM HIT

Protector around four-corner of cabinet to better protect cabinet from led damage



45 Degree Installations

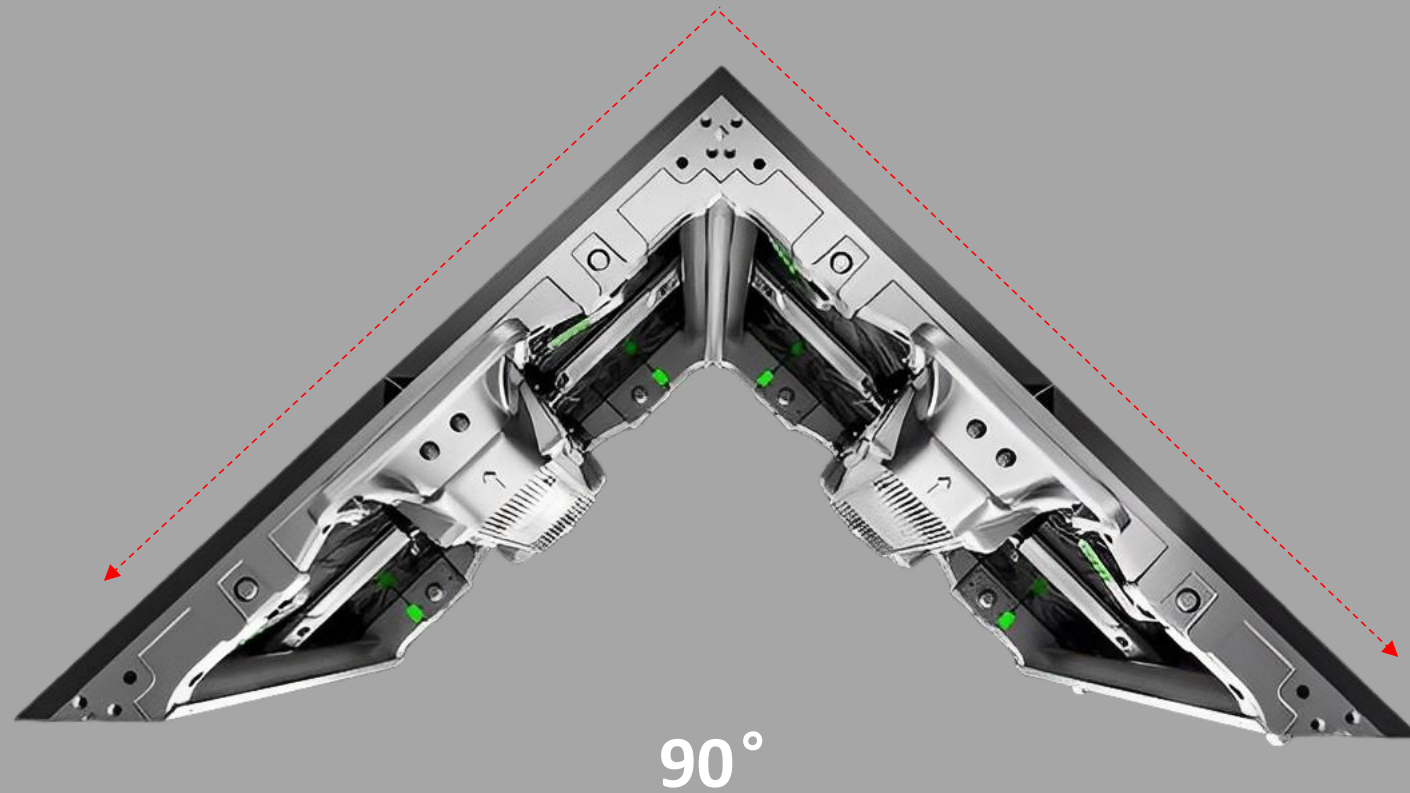

- 90 degree design
- Single cabinet 45°
- Design for special using
- Corner for Square

■ FIRST CLASS FLATNESS

- For VCH Series, the cabinet frame is produced by leading supplier for die-cast frames, well known in the industry for reliable quality control

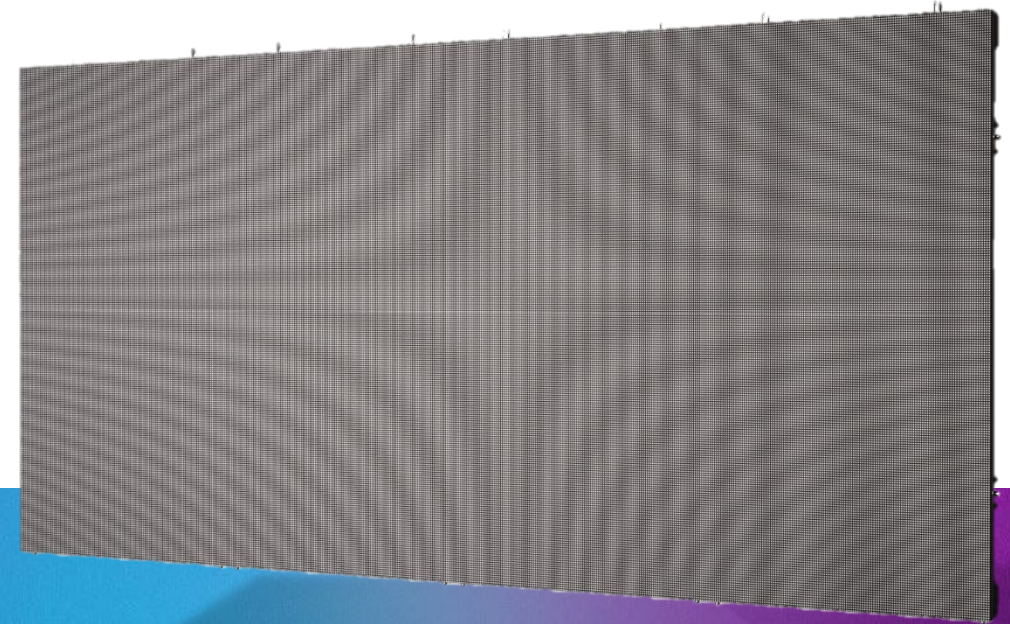

CONCAVE AND CONVEX INSTALLATIONS

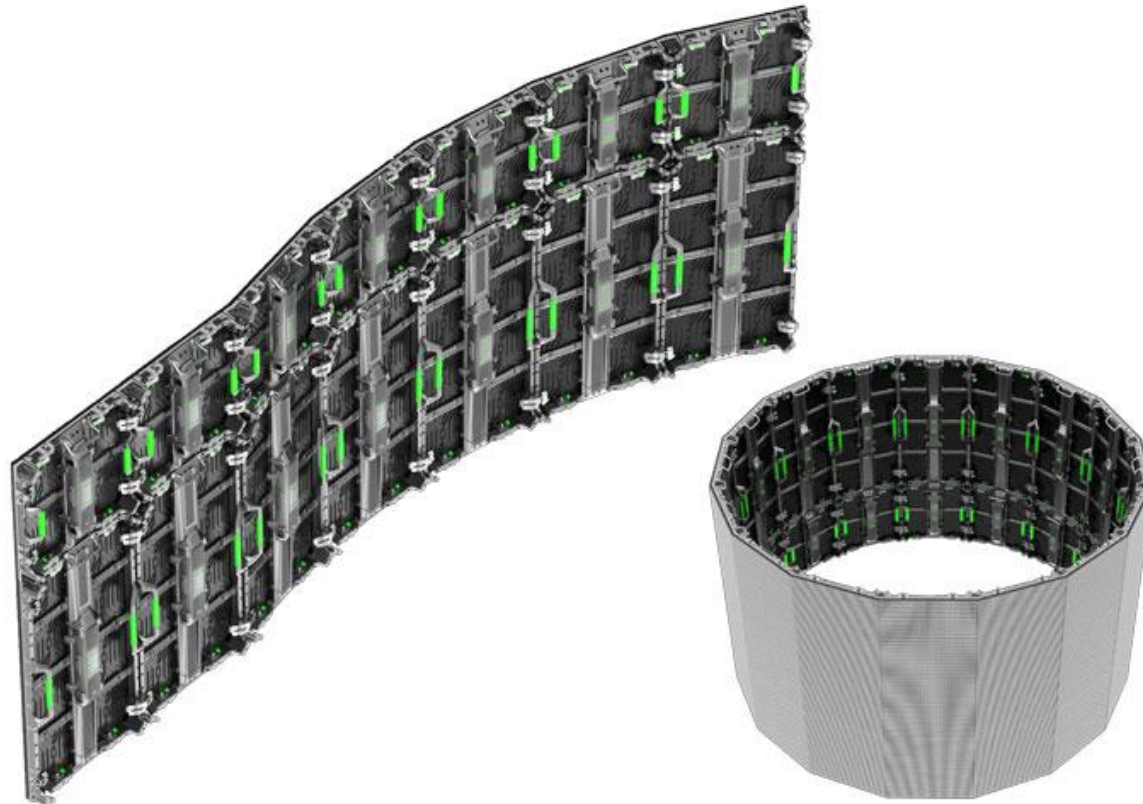

Curve cabinet unique design

Display extraordinary LED effect and visual perception

DISPLAY EFFECT

Refresh rate is up to 3840HZ, gray scale 14bit, displaying vividly



High Refresh Rate: 3840Hz

VS

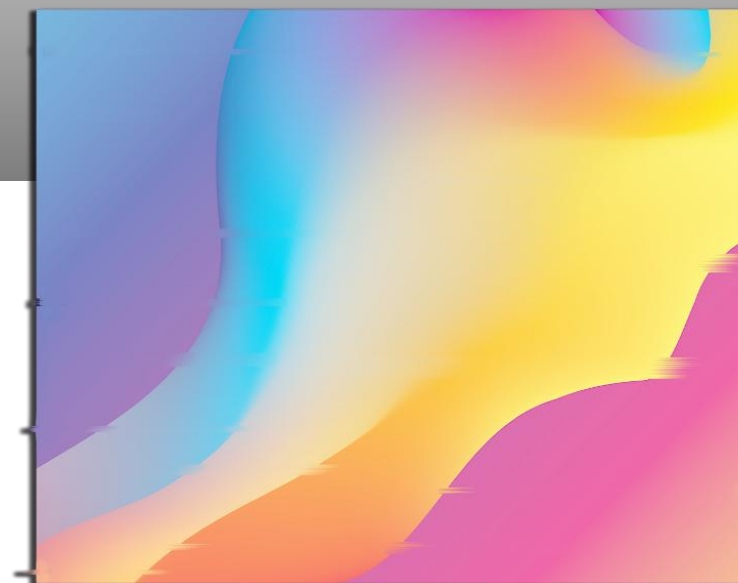

Common Refresh Rate

WIDE VISUAL ANGLE

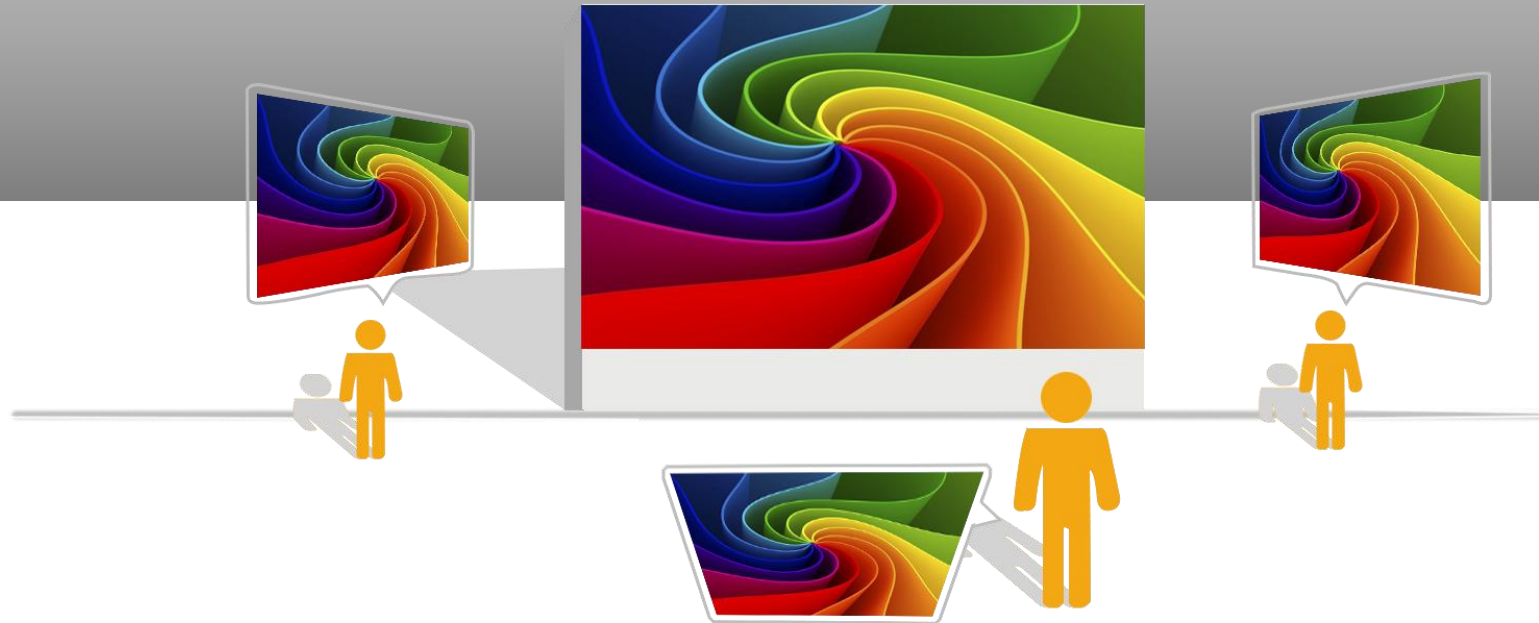

Horizontal : 170 degree, vertical : 160 degree

PART. 04

Product Specifications

Design with fast rental and super slim

Specification

VCH models

Pixel pitch	2.6mm	3.9mm	3.9mm outdoor	4.8mm outdoor
LED configuration	SMD2020	SMD2020	SMD1921	SMD1921
Brightness	1000 nits	1000 nits	5000 nits	5000nits
Viewing angle	170°/ 160°	170°/ 160°	170°/ 160°	170°/ 160°
Scan mode	1/16	1/16	1/16	1/13
Refresh rate	1920/3840/7680Hz			
Processing	14/16 bits	14/16 bits	14/16 bits	14/16 bits
Module size	250mm x 250mm x 17mm (W x H x D)			
Panel size	500mm x 500mm x 69mm (W x H x D)			
Panel weight	6.8kg/pcs			
Input voltage	AC100~240V 50/60 HZ			
Power consumption (Avg)	160W/sqm	160W/sqm	180W/sqm	180W/sqm
Power consumption (Max)	600W/sqm	600W/sqm	640W/sqm	640W/sqm
Working temperature	-20°C~60°C			
IP rating	IP42/IP31	IP42/IP31	IP65/IP54	IP65/IP54
Life span	100,000 hrs			
Warranty	24 months full warranty + 12 month free maintenance			