

# 960×960mmSeries outdoor LED display

High-end quality · Reliable Supplying

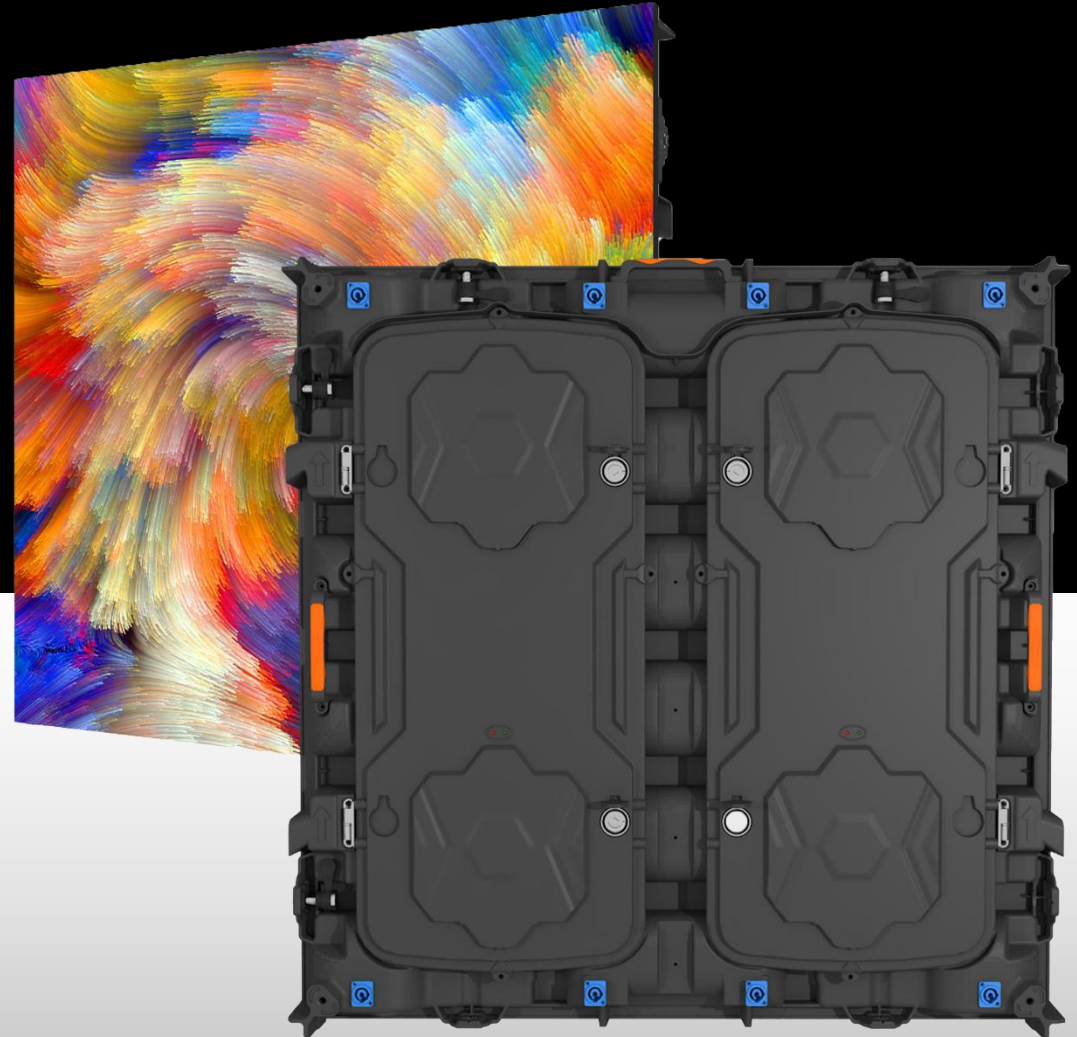

# LED显示屏规格书

## LED DISPLAY SPECIFICATION

**Model:** Vcore 960×960mm Series  
**Type:** For outdoor applications  
**Pitches:** P2.5,P3,P4,P5,P6.667,P8,P10

批 准APPROVED	审 核CHECK	制 定ORGANIZED BY
		
Version No: V-2020-2.0		
Release Date:2020-8-19		

# 960 × 960mm Series



- For outdoor rental displays
- Compatible with P2.5,P3,P4,P5,P8,P10,easy for screen upgrades
- Ultrathin, lightweight, and highly stable aluminum die casting structure
- Quick installation in 12 seconds

Size	960*960 *90mmsize
Weight	22kg/pcs
Material	Die-casting aluminum
IP protection	Indoor:IP30/ Outdoor: IP65
Pitches	P2.5,P3,P4,P5,P8,P10
Installation method	Hanging, Fixed installation
Color	optional



LIGHT WEIGHT



ULTRA THIN



FAST HEAT DISSIPATION



ANTI-INTERFERENCE



HIGH STRENGTH



QUICK INSTALLATION



HIGH PRECISION



STRONG COMPATIBILITY



EASY TO MAINTAIN



COST-EFFECTIVE

Power connector



Cabinet lock



Handle



Data Cable

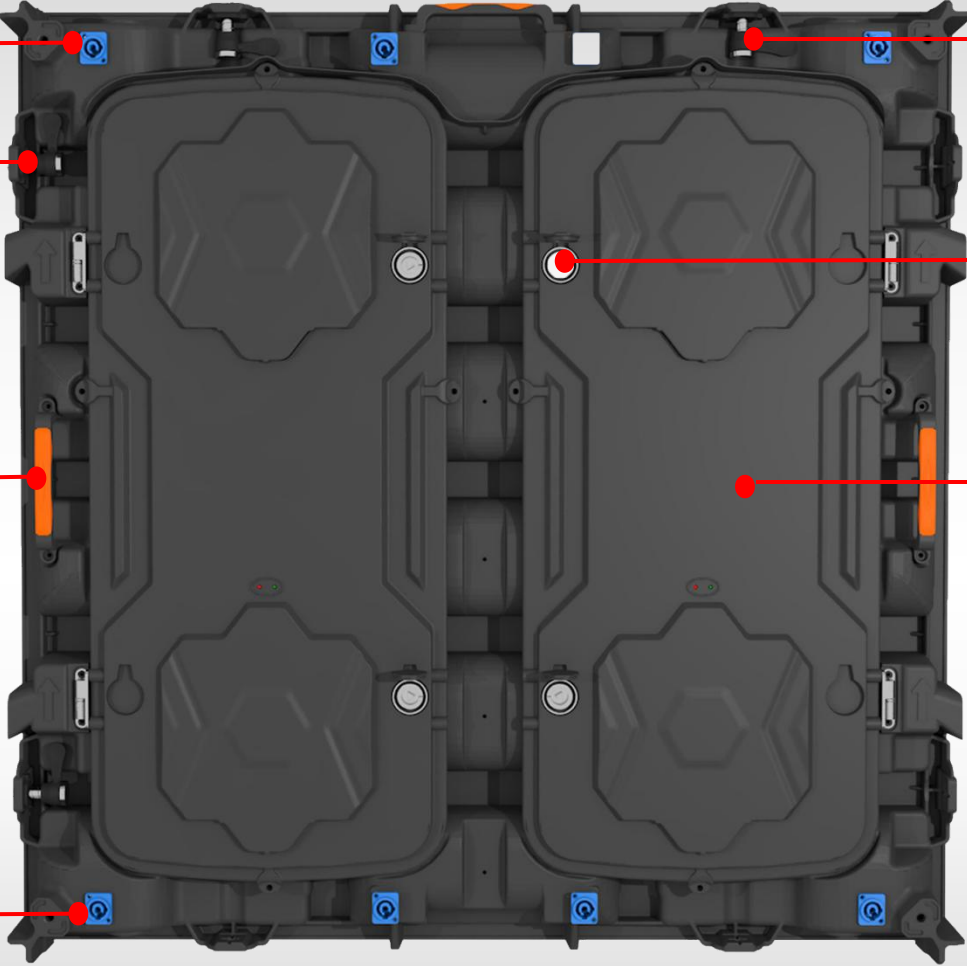

Cabinet lock



Cabinet door lock



Cabinet door





Fast Lock

Fast Installation  
50% Labor Saving



Easy Maintenance

Lifting Handle

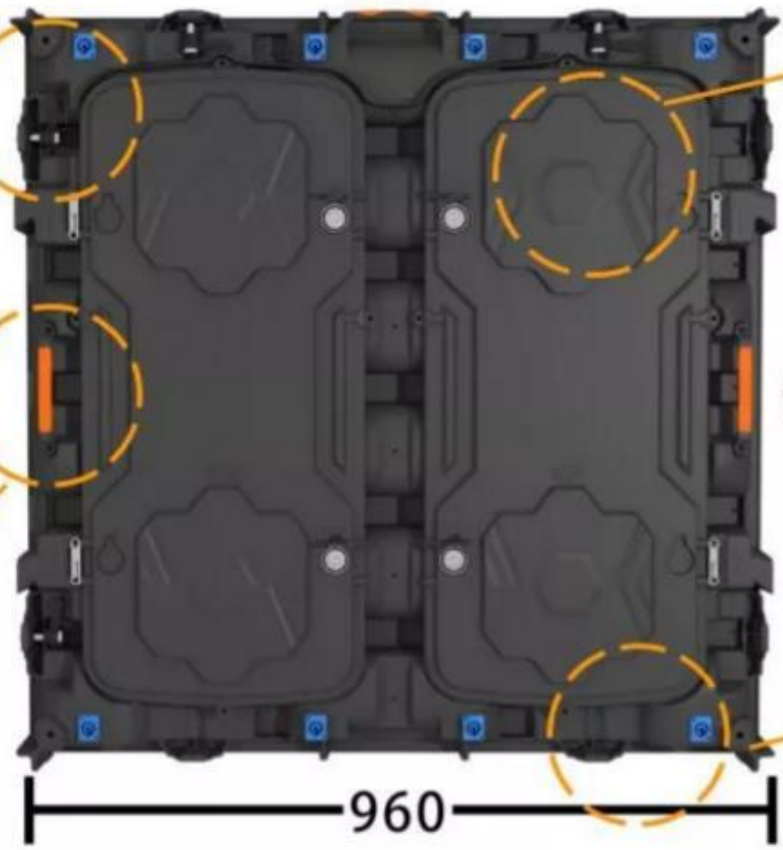

Fans



High heat dissipation

960

Pipeline Design

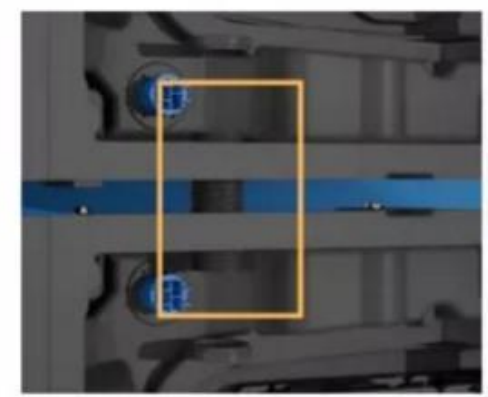

Internal wiring:  
effective circuit protection

960

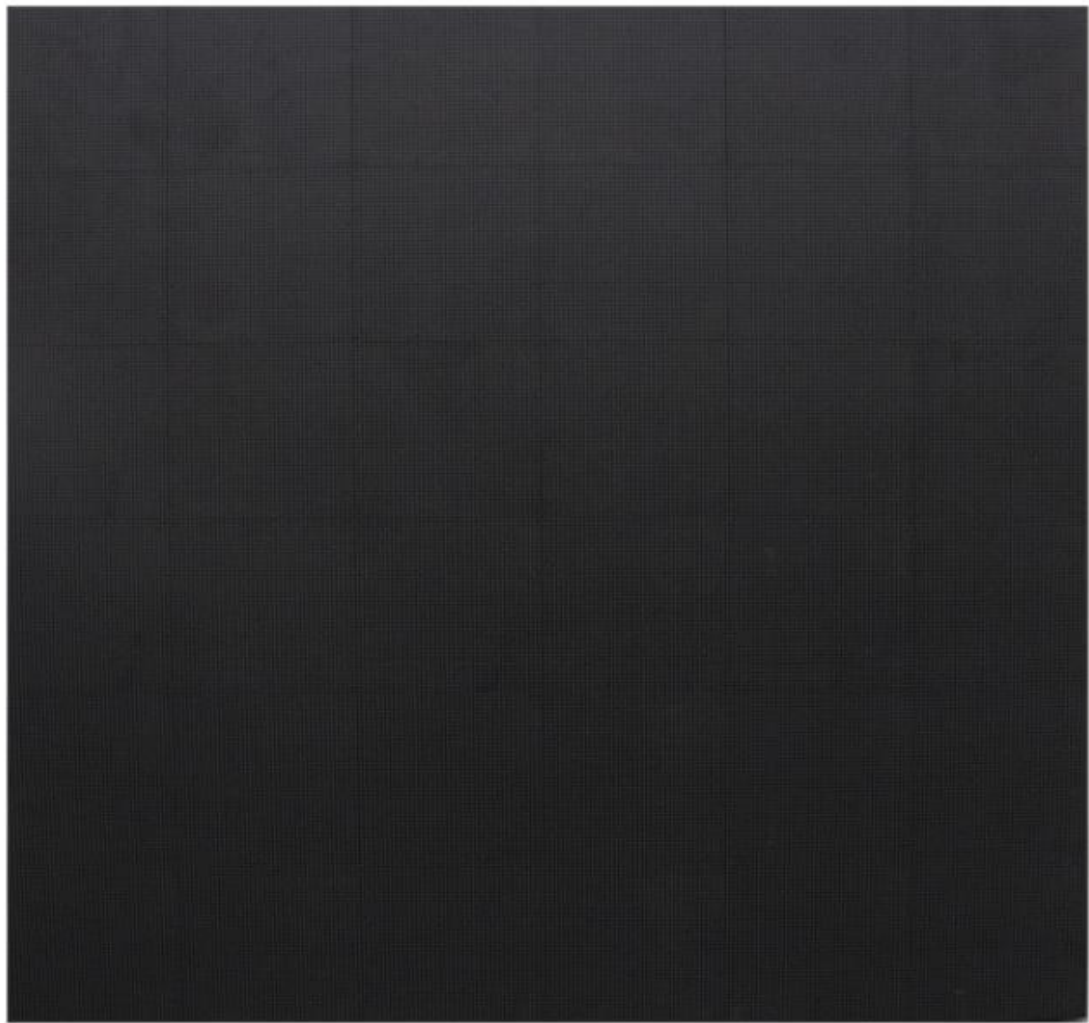

Front side

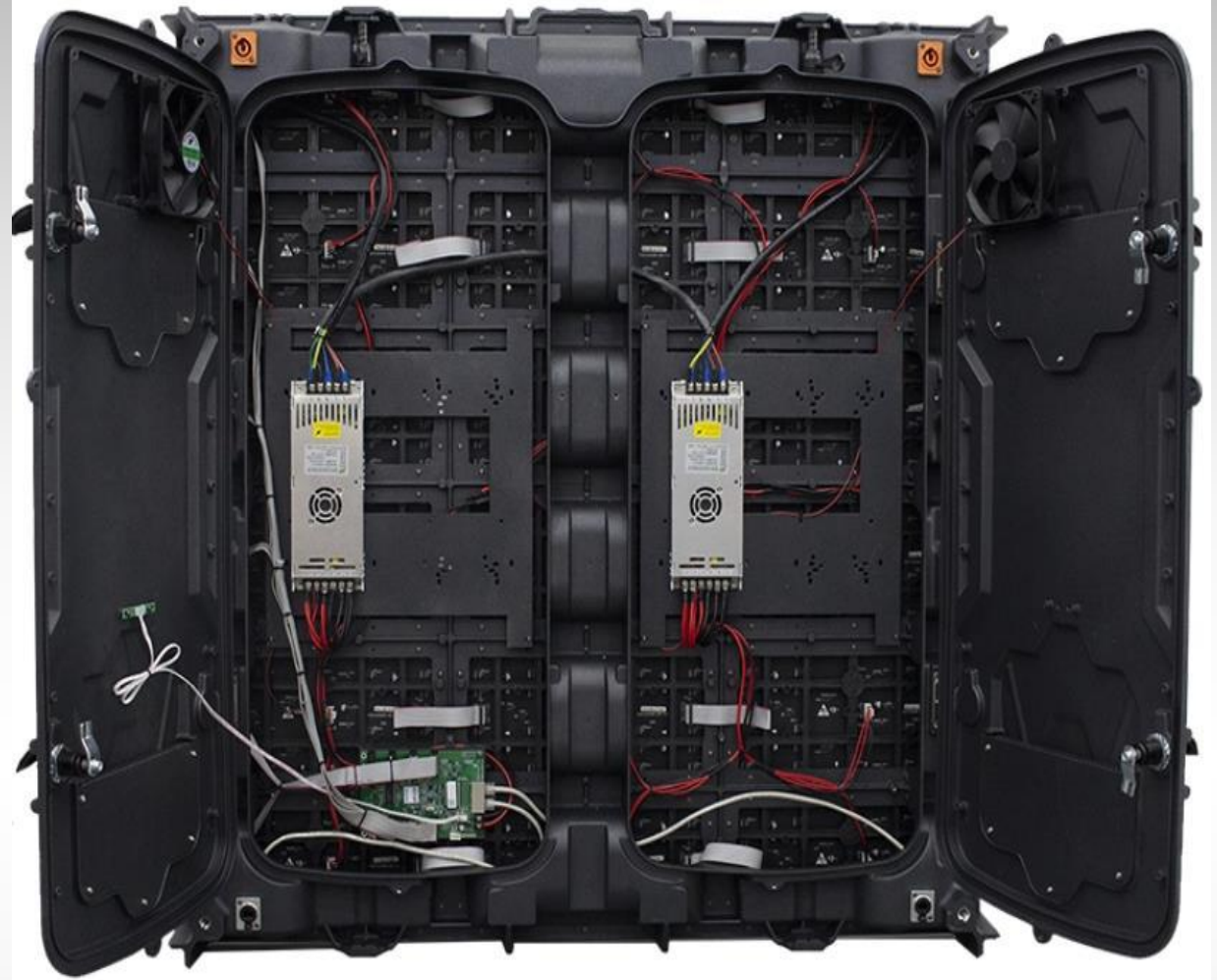

Back side(inner)

## Features

960\*960-B吊梁安装  
960\*960-B HANGING BEAM INSTALLATION

连接片连接固定  
CONNECTION PIECE FIXED

960\*960-B吊梁安装  
960\*960-B HANGING BEAM INSTALLATION

快速锁安装  
QUICK LOCK INSTALLATION

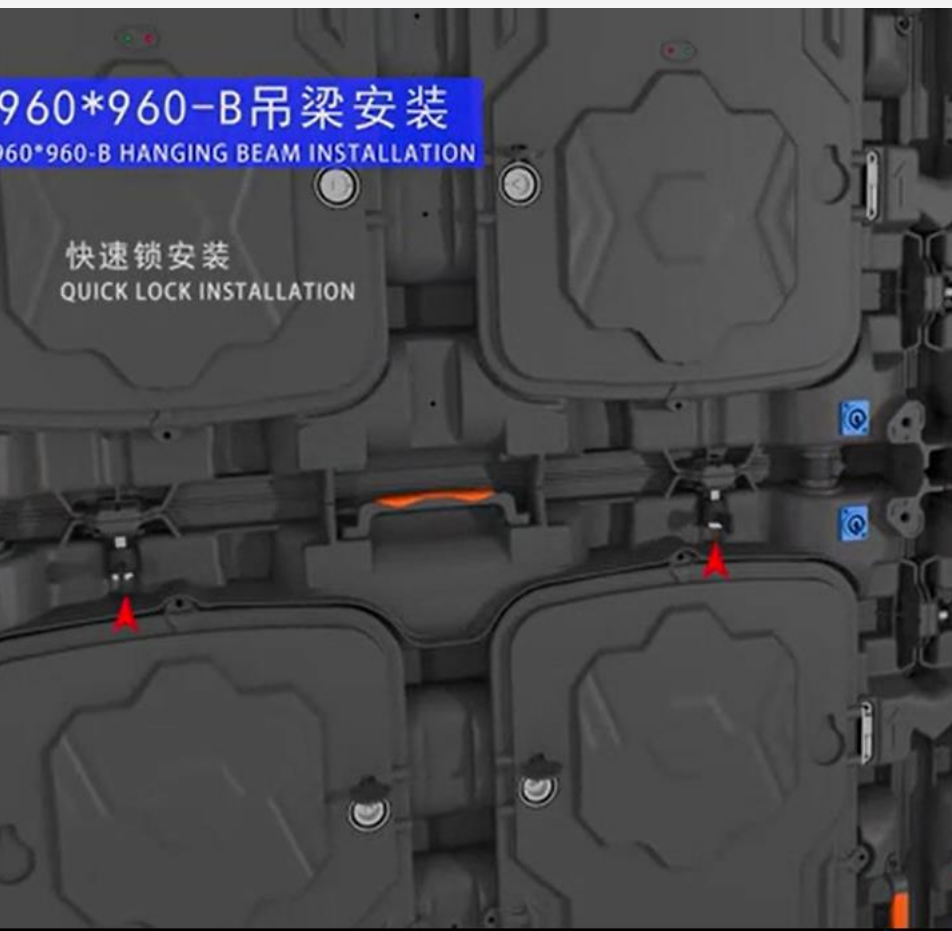



## Features



With signal and power connector, easy to interconnect

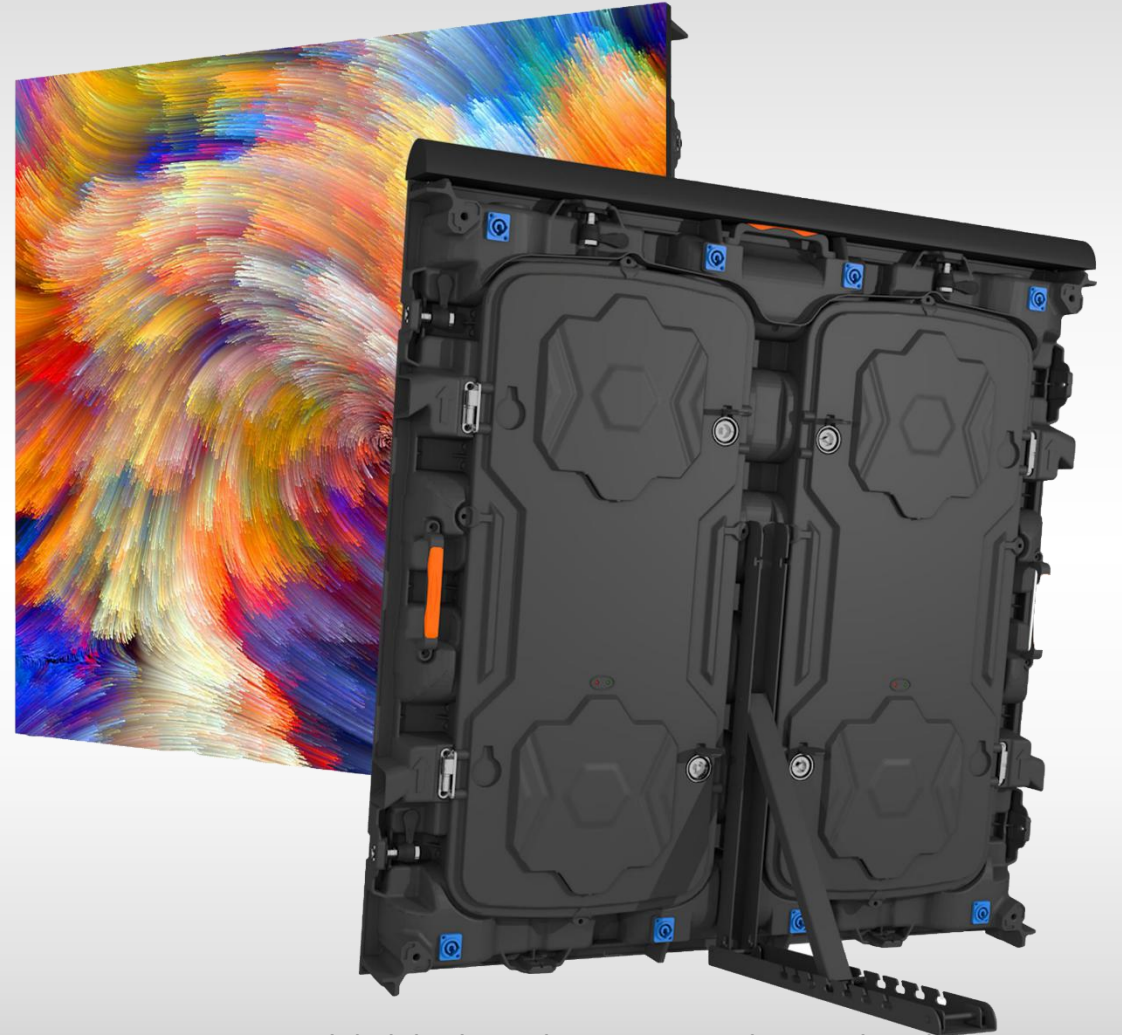

Foldable bracket, as stadium display

## Assemble line



Aging test



## Hanged LED Display

- These cabinets can be fixed to the hanging bar by upper/lower locks, or they can be fixed together by left/right locks
- Fix other cabinets from top to bottom, from the middle to both sides (the number of horizontal cabinets is not limited, and the total number of vertical height cabinets must not exceed 6)

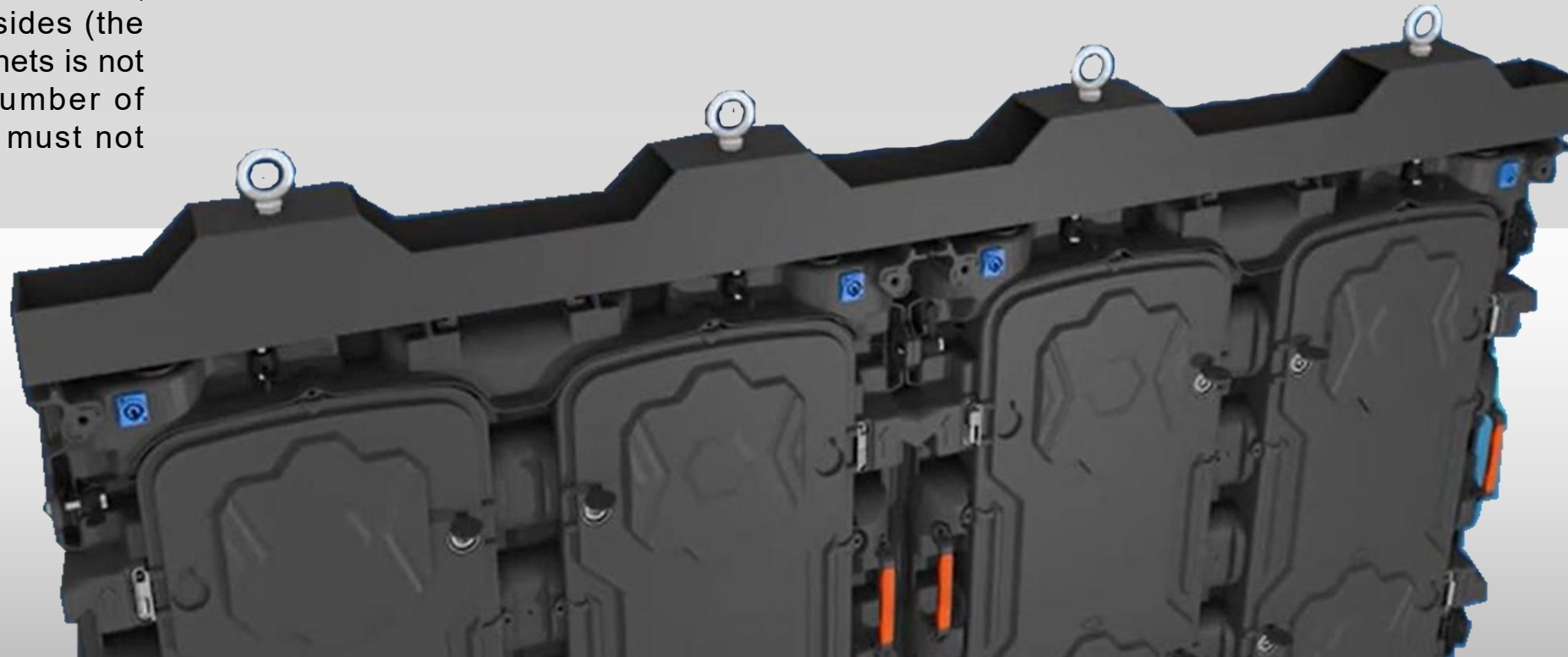

## Floor-mounted LED Display

- Install the cabinets from bottom to top, from the middle to both sides. Use locks to secure adjacent boxes.
- The number of horizontal cabinets is not limited, and the number of vertical cabinets cannot exceed 6.
- Fix the box with the connector on the back frame.
- According to the safety conditions of the installation site, add an appropriate number of counterweights to the ground support, such as sandbags, to fix the support on the ground

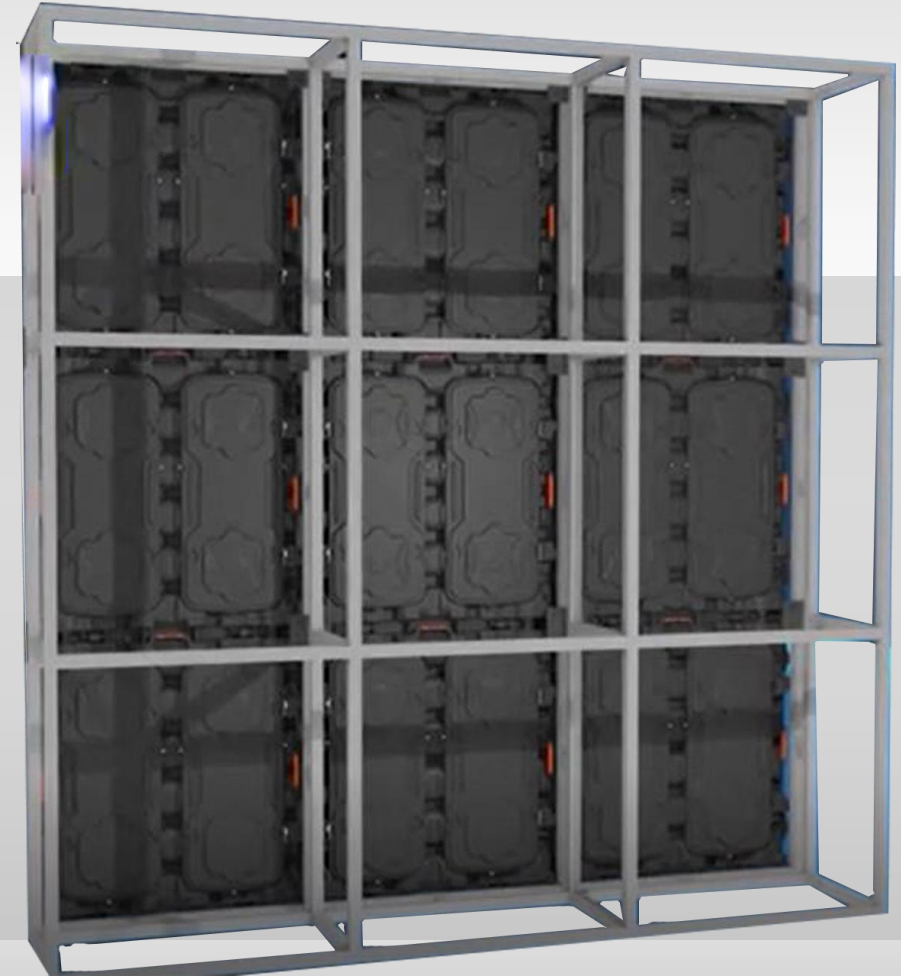

# Applications



# Outdoor led screen



Model	P2.5	P3	P4	P5
pitch	2.5mm	3mm	4mm	5mm
LED lamp	SMD1415	SMD1415	SMD1921	SMD2727
Density(dots/m <sup>2</sup> )	160000	111111 dots/m <sup>2</sup>	62500 dots/m <sup>2</sup>	40000
Cabinet resolution	384×384	320 ×320	240×240	192×192
Cabinet weight(KG)	30	30	30	30
Scan	1/32	1/32	1/16	1/8
Viewing angle	H:140°, V:120°	H:140°, V:120°	H:140°, V:120°	H:140°, V:120°
Refresh rate	≥1280hz	≥1920hz	≥1920hz	≥2880hz
Brightness	4500	5000	5000	6000
Power consumption	800W/350W			
IP protection	IP65			
Cabinet size	960mm×960mm			
Grey level	12-14bit			
Input voltage	AC220V/50Hz			
MTBF	10000H			
Lifespan	≥100000H			
Working Temp.	-20°C ~ +45°C			
Working Humidity	10% ~ 60%RH			

# Outdoor led screen



Model	P6.667	P8	P10	P10
pitch	6.67mm	8mm	10mm	10mm
LED lamp	SMD2727	SMD2727	SMD3535	SMD3535
Density(dots/m <sup>2</sup> )	22500dots/m <sup>2</sup>	15625 dots/m <sup>2</sup>	10000 dots/m <sup>2</sup>	10000 dots/m <sup>2</sup>
Cabinet resolution	144×144	320 ×320	240×240	192×192
Cabinet weight(KG)	30	30	30	30
Scan	1/6	1/5	1/2	1/4
Viewing angle	H:140°, V:120°	H:140°, V:120°	H:140°, V:120°	H:140°, V:120°
Refresh rate	≥2880hz	≥3840hz	≥3840hz	≥3840hz
Brightness	6000	6000	7000	6000
Power consumption	800W/350W			
IP protection	IP65			
Cabinet size	960mm×960mm			
Grey level	12-14bit			
Input voltage	AC220V/50Hz			
MTBF	10000H			
Lifespan	≥100000H			
Working Temp.	-20°C ~ +45°C			
Working Humidity	10% ~ 60%RH			



# LED display Precautions & Maintenance

## Note for turning off the screen

1. Turn on the screen: first turn on the control computer to make it run normally, then turn on the LED screen;

- 1) Start the distribution box of the LED display.
- 2) Start the control computer.
- 3) Start the video processor.
- 4) Start the sending box.

2. Turn off the screen: first turn off the power of the LED screen, turn off the control software, and then turn off the computer correctly; (first turn off the computer but turn on the display , it will cause bright spots on the screen then burning the lamp, will result in serious consequences))

- 1) Turn off the video processor.
- 2) Close the sending box.
- 3) Close the controlling PC.
- 4) Turn off the distribution box of the LED display.

3. The switching screen time interval should be greater than 5 minutes;

- 1) Avoid turning on the screen in the state of full white screen, because it is the maximum power state at this time, which has the largest current for the entire power distribution system.

## ● Electricity Precautions

- 1) The LED module is DC +5V power supply (working voltage: 4.2-5.2V), AC power supply is prohibited; the positive and negative poles of the power terminals are strictly prohibited to be reversed (note: once the reverse is connected, the product will be burnt out and even cause serious fire) ;
- 2) Power supply voltage of LED display:  $220 \pm 10\%$  frequency;  $50\text{Hz} \pm 5\%$ ;
- 3) Safe and reliable ground contact, reliable distance between the ground wire and the neutral wire, and keep the power supply away from high-power equipment;
- 4) If abnormal phenomena such as short circuit, tripping, wire burning, smoke, etc. are found, the power-on test should not be repeated, and the problem should be checked in time;
- 5) Keep the power supply stable, and do grounding protection to avoid lightning strikes. Do not use it under harsh natural conditions, especially strong lightning weather;
- 6) The large screen must be powered step by step, because the maximum power state of the entire screen will have an impact on the entire power distribution system;
- 7) The LED display screen is not allowed to play the full white screen with the highest brightness for more than half an hour, so as to avoid excessive current, heating of the power cord, damage to the LED lamp beads, and affect the service life of the display. It is recommended to play dynamic videos;
- 8) Non-professionals are forbidden to touch the internal wiring of the LED display screen to avoid electric shock or data wiring errors.

## ● Cleaning instructions

- 1) Regular cleaning and maintenance: After the LED display is used for a long time, more dust will accumulate on the screen and the rain will be washed away. This requires regular and timely cleaning to prevent it from affecting the viewing effect.
- 2) If you need to clean the surface of the module, please use a soft brush and gently wipe it. Do not use any liquid substance to clear the surface of the LED module, otherwise it may cause damage to the LED lamp beads;
- 3) Wipe correctly: The surface of the large screen of the LED display can be wiped with alcohol, or use a soft brush or vacuum cleaner to remove dust, but not directly with a wet wipe.

## ● Working & storage environment requirements

- 1) The storage temperature and humidity requirements of the display screen: The ideal working environment temperature is  $20^{\circ}\text{C} \pm 10^{\circ}\text{C}$ ; the ideal working environment relative humidity is 30%-70% without condensation. LED large screens should be avoided from working or storing for a long time in a humid environment. The humid environment can easily cause oxidation and corrosion of the circuit board. (Special reminder: After the outdoor screen is exposed to rain, be sure to clean up the water stains on the screen in time to prevent moisture from entering the components and causing internal lamp beads or circuit board damage))
- 2) According to the condition of the display body and electronic components, the environment where the LED display is operated or stored should be free of dust, which will affect the display effect, and metal dust will damage the circuit or even short-circuit.

- **Moisture-proof requirements and treatment**

1) The LED display should not be turned off for a long time. If the screen has not been used for more than 3 days, the pre-hot spot light method is required to turn on the screen every time: 30%-50% brightness first preheat 4-8 Hour, then adjust to normal brightness (80%-100%), so as to remove the moisture, so that there is no abnormality in use; if the screen body has not been lit for more than 7 days, the preheating time in the pre-heating mode Up to 12 hours or more

- **Hardware maintenance**

1) If there is a problem with the display, you should first contact the professional technicians in the factory to find out the troubleshooting, and it is strictly forbidden to disassemble it without permission.